

Review

Organic light-emitting diode (OLED) technology: materials, devices and display technologies

Bernard Geffroy,^{1*} Philippe le Roy² and Christophe Prat²

¹CEA/DRT/LITEN/DSEN/GENEC, Laboratoire Cellules et Composants, CEA/Saclay, 91191, Gif-sur-Yvette Cedex, France

²Thomson R&D France, New Display Technologies, Research and Innovation, 1, Avenue Belle Fontaine - CS 17616, 35511 Cesson Sevigne, France

Abstract: Since the breakthrough by Kodak in 1987, organic light-emitting diodes (OLEDs) have been seen as one of the most promising technologies for future displays. A number of materials have been developed and improved in order to fulfil the requirements of this application. The materials differ from one another by their structure but also by the mechanism involved in the electroluminescence produced (fluorescence versus phosphorescence). When properly stacked, these materials result in a device that can achieve the required high efficiency and long lifetime. Such red, green and blue devices can then be combined in matrices to become the core of a display. Building up these structures onto a display backplane is one of the challenges facing the industry. The circuitry for driving the pixels can be adapted to the OLED, sometimes at the expense of the simplicity of the display, but bearing in mind that the fabrication process must remain industrially viable.

© 2006 Society of Chemical Industry

Keywords: organic light-emitting diode (OLED); flat-panel display; passive matrix; active matrix; full-colour device

INTRODUCTION

During the last two decades, organic light-emitting diodes (OLEDs) have attracted considerable interest owing to their promising applications in flat-panel displays by replacing cathode ray tubes (CRTs) or liquid crystal displays (LCDs). Electroluminescence is the emission of light from materials in an electric field, and in the 1960s¹ this phenomenon was observed from single crystals of anthracene. Despite the high quantum efficiency obtained with such organic crystals, no application has emerged owing to the high working voltage required as a result of the large crystal thickness and poor electrical contact quality. Nevertheless, these studies have led to a good understanding of the basic physical processes involved in organic electroluminescence, i.e. charge injection, charge transportation, exciton formation and light emission. A first breakthrough was achieved in 1987 by Tang and Van Slyke² from Kodak when they reported efficient and low-voltage OLEDs from p-n heterostructure devices using thin films of vapour-deposited organic materials. Another development of technological interest was the 1990

discovery of electroluminescence from polymers at the University of Cambridge.³ The key advantages of OLEDs for flat-panel display applications are their self-emitting property, high luminous efficiency, full-colour capability, wide viewing angle, high contrast, low power consumption, low weight, potentially large area colour displays and flexibility. Several approaches have been described to build full-colour displays,⁴ such as side-by-side patterning of discrete red (R), green (G) and blue (B) sub-pixels, RGB tuneable pixels, filtering of white OLEDs, down-conversion of blue-emitting OLEDs or filtering of broad-band-emitting OLEDs.

In this paper, after some general considerations, an overview of materials and device structures is presented with particular focus on electroluminescence efficiency and device lifetime. The display technology is then discussed.

MATERIALS AND DEVICE STRUCTURES

The basic structure of an OLED consists of a thin film of organic material sandwiched between two

* Correspondence to: Bernard Geffroy, CEA/DRT/LITEN/DSEN/GENEC, Laboratoire Cellules et Composants, CEA/Saclay, 91191, Gif-sur-Yvette Cedex, France

E-mail: bernard.geffroy@cea.fr

(Received 8 July 2005; revised version received 6 October 2005; accepted 8 November 2005)

Published online 6 February 2006

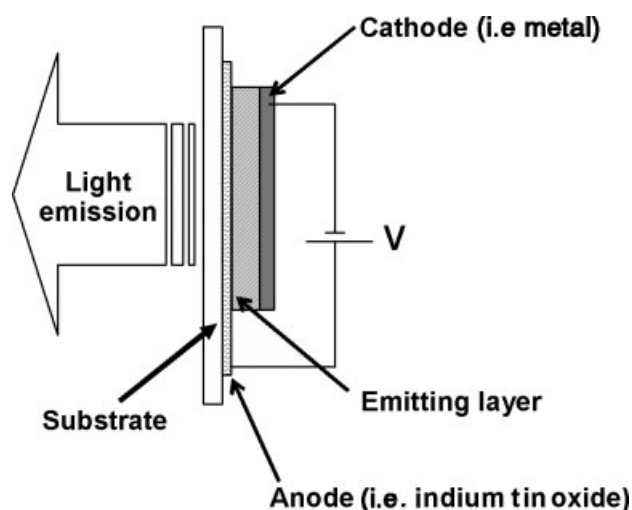
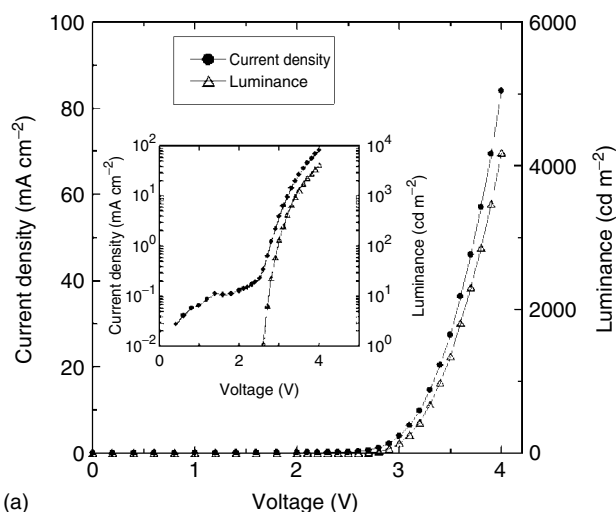

Figure 1. Basic OLED device structure.

electrodes, as depicted in Fig. 1. Organic electroluminescent (OEL) materials, based on π -conjugated molecules, are almost insulators, and light is produced by recombination of holes and electrons which have to be injected at the electrodes. The anode is transparent and is usually made of indium tin oxide (ITO), while the cathode is reflective and is made of metal. The thickness of the organic layer is very thin, between 100 and 150 nm. When a voltage is applied between the electrodes, charges are injected in the organic material, holes from the anode and electrons from the cathode. Then, the charges move inside the material, generally by hopping processes and then recombine to form excitons. The location of the recombination zone in the diode is a function of the charge mobility of the organic material as well as of the electric field distribution. After diffusion, the exciton recombines and a photon is emitted.

The colour of the photon is a function of the energy difference between the highest occupied molecular orbital (HOMO) and the lowest unoccupied molecular orbital (LUMO) levels of the electroluminescent molecule. The wavelength of the light emission can thus be controlled by the extent of the conjugation in the molecule or the polymer. For efficient hole injection from the anode, a low barrier is required in respect of the HOMO level of the organic material (typically 5–6 eV). ITO is usually used for the anode because of its high work function as well as its good transparency in the visible range. Hole injection is further enhanced by oxygen plasma treatment of the ITO.^{5,6} On the cathode side, a low barrier for electrons is needed in respect of the LUMO level of the organic material (typically 2–3 eV). Low work function metals such as Ca and Mg are required but they are very sensitive to moisture, and more stable cathodes have been introduced, such as Mg/Ag alloys⁷ or Al in combination with alkali metal compounds.⁸ A thin LiF layer^{9–11} (~1 nm) capped with a thicker Al layer is widely used as the cathode, and many other insulating layers such as CsF,¹² MgO,⁹



(a)

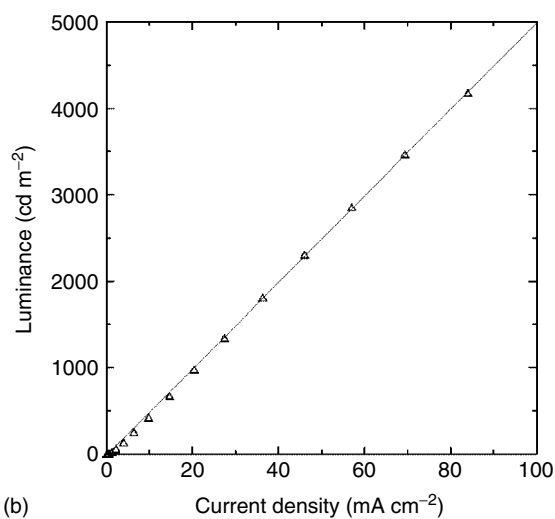

(b)

Figure 2. Typical *I-V-L* characteristics of OLEDs (a) and luminance versus current density (b). The inset in (a) shows the current and luminance thresholds.

Al_2O_3 ¹³ and NaCl ¹⁴ have been studied in order to enhance electron injection. For the LiF/Al cathode, the electron injection enhancement has been explained by various mechanisms, such as a tunnelling effect, band bending at the metal/organic interface, the formation of interfacial dipoles or chemical dissociation of the LiF layer during Al evaporation. The typical *I-V-L* (current-voltage-luminance) characteristics of OLEDs are shown in Fig. 2(a). Above the threshold voltage, the current increases exponentially and light is emitted. Generally, the luminance is proportional to the current density (Fig. 2(b)), indicating that the quantum efficiency is constant over a wide range of current.

Two types of electroluminescent materials are used: small molecules (SM-OLED) and polymers (PLED). The electroluminescence performance is generally very similar for the two classes of material and the main difference is the deposition process of the thin organic film. While SM materials are generally deposited by evaporation under vacuum (referred to as a 'dry process'), PLED materials are processed

from solutions (a 'wet process'). Devices based on SM materials allow more layer engineering and more sophisticated architecture compared with PLED devices. In organic materials used for OLEDs, the intrinsic density of charge is very low ($\sim 10^{-10} \text{ cm}^{-3}$), but it is possible to increase the conductivity by doping the host material with acceptor or donor species in order to create charge carriers. It has been demonstrated that the luminous efficiency of OLED devices can be significantly improved by doping the hole transport layer with a strong electron acceptor.^{15,16}

The efficiency of an OLED is characterized by its quantum efficiency, the current efficiency in cd A^{-1} (η_L) or the luminous efficiency (η_P) in lm W^{-1} . For the quantum efficiency, two different parameters have to be taken into account: the external quantum efficiency (η_{ext}) and the internal quantum efficiency (η_{int}). η_{ext} is defined as the number of emitted photons divided by the number of injected charges, is given by:¹⁷

$$\eta_{\text{ext}} = \eta_r \phi_f \chi \eta_{\text{out}} = \eta_{\text{int}} \eta_{\text{out}}$$

where η_r is the probability that holes and electrons recombine to form excitons. Owing to the low mobility of the charge carriers, the probability of charge recombination or exciton formation in organic materials is nearly equal to 1. Nevertheless, the efficiency of OLEDs is determined to a significant extent by the efficiency of electron and hole injection into the organic layers, and in order to maximize η_r a good balance between the two types of charge is desired. ϕ_f is the fluorescent quantum efficiency or the fraction of excitons that decays radiatively. In organic materials, and particularly in doped systems, the ϕ_f can approach 100%. χ is the probability for radiative decay to occur, and generally only singlet excitons emit light. According to spin statistics, the fraction of singlets is $\chi = 1/4$.¹⁸ It has been reported that for polymer materials, χ could take higher values.¹⁹ Nevertheless, as will be discussed later in the paper, certain particular triplet emitters containing a heavy atom can allow singlet to triplet energy transfer through intersystem crossing, which leads to highly efficient devices where 100% of the excitons can produce light, in contrast to only 25% in conventional fluorescent devices. η_{out} is the fraction of photons that can escape the device and is limited by waveguiding in the device layers and the substrate. It has been demonstrated that in planar structures such as OLEDs²⁰ $\eta_{\text{out}} \approx 1/(2n^2)$ with n being the refractive index of the organic material and assuming $n = 1.7$ (typical of organics used in OLEDs), η_{out} is typically around 17%. In conventional fluorescent OLEDs, the maximum external quantum efficiency is thus limited to 5%.

The current efficiency (η_L), expressed in cd A^{-1} , is another way to characterize the quality of a device and represents the ratio of the luminance (L) to the current density (\mathcal{J}) flowing into the diode. The

luminous efficiency (η_P) expressed in lm W^{-1} is the ratio of the optical flux to the electrical input and is given by:

$$\eta_P = \frac{L\pi}{\mathcal{J}V} = \eta_L \frac{\pi}{V}$$

where V is the working voltage.

Thus, devices with high luminous efficiency have to combine high quantum (or current) efficiency with a low working voltage. Note that η_L and η_P are functions of eye sensitivity (photopic response), which is maximum in the green range and therefore the current or luminous efficiency is lower in the blue and the red part of the spectrum in comparison with green, assuming devices with the same quantum efficiency and working voltage.

Materials and efficiencies

The main requirements for OLED materials are high luminescence quantum yield in the solid state, good carrier mobility (both n and p type), good film-forming properties (pinhole free), good thermal and oxidative stability, and good colour purity (adequate CIE coordinates). The first generation of efficient devices, pioneered by Tang and Van Slyke² from Eastman Kodak, was based on fluorescent materials. In this case, the emission of light is the result of the recombination of singlet excitons, but the internal quantum efficiency is limited to 25%. Typical examples of fluorescent RGB materials are shown in Table 1.

The second generation uses phosphorescent materials where all excitons can be converted into emissive triplet states through efficient intersystem crossing. Such materials are up to four times more efficient than fluorescent materials. The presence of heavy atoms such as iridium or platinum increases spin-orbit coupling, favours intersystem crossing and allows radiative triplet transitions. Baldo *et al.*³⁰ were the first to report the use of green phosphorescent dye to increase the device efficiency. Highly efficient green and red electrophosphorescent emitters have been demonstrated with internal quantum efficiencies approaching 100%.^{31,32} The highest luminous efficiency of 70 lm W^{-1} reported up to now was obtained by Ikai *et al.*³³ using tris(2-phenylpyridine)iridium(III) ($\text{Ir}(\text{ppy})_3$) phosphorescent dye in an improved device structure. Phosphorescent materials have also been used in polymer technology (wet process).³⁴

The materials used for OLEDs are amorphous or semi-crystalline films. For SM-OLED, typical p-type materials are derivatives of triaryl amines, and n-type materials consist of derivatives of metal chelates such as tris(8-hydroxyquinolato)aluminium(III) (Alq_3), triazoles or oxadiazoles. The efficiency is improved by doping the emitting layer with various organic dyes as shown in Table 1. Generally the doping rate is about 1–2 wt% and this solution has been widely used to tune the colour and to improve the device lifetime. It has been demonstrated that by doping

Table 1. Typical RGBW electroluminescence characteristics of SM-OLEDs based on fluorescent materials

Colour	Material	CIE		Efficiencies			Reference
		x	y	η_{ext} (%)	cd A ⁻¹	lm W ⁻¹	
Blue	DSA-doped DPVBi	—	—	2.4	2.8	1.5	21
	BCzVB-doped CBP	0.15	0.16	2.6	3.5	—	22
	BCzVB-doped DPVBi	0.15	0.14	5.7	7.0	—	23
	DPVBi	0.16	0.14	—	1.8	1.1	24
	SAIq	0.17	0.19	3.0	6.9	2.0	25
Green	Alq ₃	—	—	1.3	—	—	7
	QA-doped Alq ₃	—	—	3.0	—	—	26
	coumarin-doped Alq ₃	—	—	2.5	—	—	7
	Alq ₃	0.39	0.55	—	2.6	—	27
	DMQA-doped Alq ₃	0.39	0.59	—	7.3	—	28
Red	DCM-doped Alq ₃	—	—	—	—	—	7
	DCJTB-doped Alq ₃	0.64	0.36	—	2.5	0.9	29
	DCJTB- and rubrene-doped Alq ₃	0.64	0.35	—	3.2	1.2	29
White	DPVBi/Alq ₃	0.28	0.34	—	4.7	2.9	24
	DCJTB-doped SAIq	0.33	0.39	2.0	6.6	2.3	25
	PAP-ph + Alq ₃ + DCM-doped Alq ₃	0.35	0.34	1.9	3.9	2.0	29

Alq₃ = tris(8-hydroxyquinolato)aluminium(III).

BCzVB = 4, 4'-(bis(9-ethyl-3-carbazovinyleno)-1,1'-phenyl).

CBP = 4, 4'-N, N'-dicarbazole-biphenyl.

DCJTB = 4-(dicyanomethylene)-2-t-butyl-6(1,1,7,7-tetramethyljulolidyl-9-enyl)-4H-pyran.

DCM = 4-(dicyanomethylene)-2-methyl-6-(p-dimethylaminostyryl)-4H-pyran.

DMQA = N, N'-dimethylquinacridone.

DPVBi = 4, 4'-bis(2,2'-diphenylvinyl)-1,1'-biphenyl.

DSA = distyrylarylene.

PAP-ph = 1,7-diphenyl-4-biphenyl-3,5-dimethyl-1,7-dihydrodipyrzolo[3,4-b;4', 3'-e]pyridine.

QA = quinacridone.

SAIq = bis(2-methyl-8-quinolato)-(triphenylsiloxy)aluminium(III).

the host Alq₃ with various guest molecules such as coumarin 540 (C540), 2,4-bis(dicyanomethylene)-6-(p-dimethylaminostyryl)-4H-pyran (DCM1) or [2-methyl-6-[2-(2,3,6,7-tetrahydro-1H,5H-benzo[ij]quinolizin-9-yl)ethenyl]-4H-pyran-4-ylidene]propanedinitrile (DCM2), the electroluminescence efficiency can be improved by a factor of two at least.⁷ Furthermore, by using these dopants, a wide range of colours from greenish-blue to orange-red can be obtained.

Device structures

The historical evolution of OLED architectures is shown in Fig. 3. For SM-OLEDs an increase in the complexity of the devices has been reported in the literature. The first studies on anthracene in the 1960s used a simple monolayer structure, and since the breakthrough of the Kodak group, more and more layers have been used with specialized functions such as the hole injecting layer, hole transporting layer, hole blocking layer, emitting layer, and electron transporting layer. It has been shown that the electroluminescence efficiency of OLEDs can be increased by carrier or exciton confinement within a multilayer device.^{35,36} The confinement of charge carriers can increase the capture of carriers, and the confinement of excitons can improve the energy transfer from the host to the guest. In comparison, the PLED technology uses a more simple structure

which consists of two or three polymer layers only. More recently, a very promising approach for low-power display technology has been demonstrated by Leo's group³⁷ at the University of Dresden by combining electrically doped transport layers and a phosphorescent-doped emitting layer in a diode structure called a p-i-n junction.

In most reported device structures, the light is seen from the substrate side (bottom emission) but it is also possible to build devices where the light escapes from the last deposited layer^{38,39} (top emission). The top-emitting OLED structure allows easier integration with backplane electronics such as silicon active-matrix addressing, but requires the use of a transparent top electrode instead of a classical opaque thin metal cathode. Many research groups are currently investigating highly transparent top electrodes, and the most advanced and reliable technology is based on a thin semi-transparent metal electrode instead of ITO deposition, which is difficult to implement for large-area devices such as displays. A top-emitting structure based on inverted organic layers (anode as top electrode) has recently been demonstrated by Dobbertin *et al.*⁴⁰ The OLED stack is protected by a thick pentacene layer before ITO (anode) deposition in order to reduce organic layer damage induced by the sputtering process. Such an inverted OLED structure allows the use of n-channel field-effect transistors for pixel driver backplanes in active-matrix displays.⁴¹

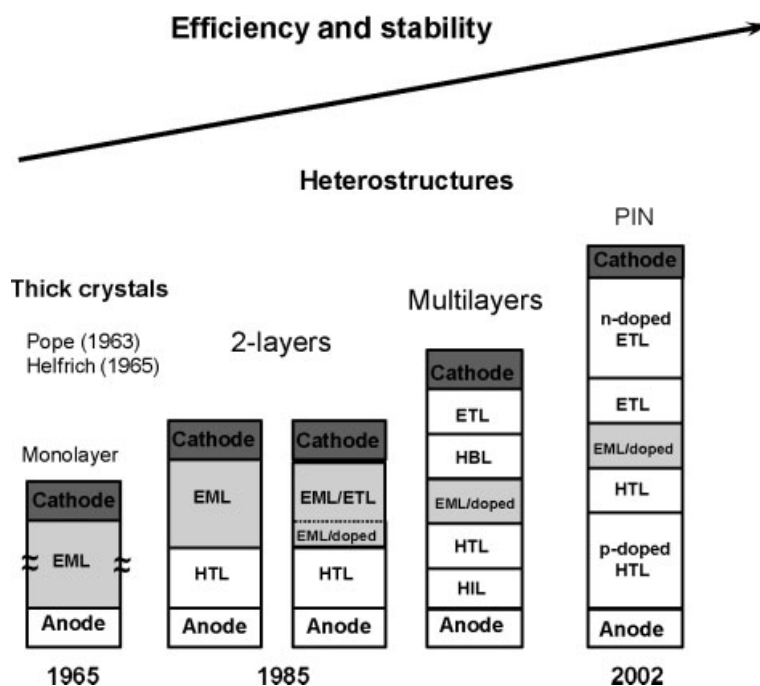

Figure 3. Evolution of OLED device structures (HIL = hole injecting layer, HTL = hole transporting layer, EML = emitting layer, HBL = hole blocking layer, ETL = electron transporting layer).

As in the case of inorganic semiconductors, organic multiple-quantum-well (MQW) structures have also been fabricated consisting of alternating layers of doped and undoped organic material.^{42–44} It has been shown that the MQW structure can efficiently control the hole–electron balance and thus improve both the device efficiency and lifetime. MQW devices have a shorter emission peak wavelength and a narrower FWHM (full width at half-maximum) of the electroluminescence spectrum compared with the conventional structure. Their better performance is explained by the confinement effect due to the MQW structure. Very recently, a new structure, called tandem OLEDs, using multiple electroluminescence units connected in series by using a doped p–n junction have been fabricated.⁴⁵ The luminous efficiency and the driving voltage have been found to scale almost linearly with the number of connected units and values as high as 32 and 132 cd A^{-1} have been obtained for devices using a fluorescent or a phosphorescent emitter, respectively.

Lifetime and device stability

Device stability is an important issue for an emissive technology such as OLEDs, and particularly differential ageing of the three primary colours. Despite the absence of any standardized measurement method, the device lifetime is usually defined as the mean time to half-brightness. It is generally assumed that for display applications, except probably for portable electronics, a lifetime of over 20 000 h with a reasonable brightness level of at least 100 cd m^{-2} is necessary. Nevertheless, as discussed later in this paper, to achieve such a level of display brightness, the luminance of each pixel needs to be much higher, and it has been widely

shown that the lifetime of OLEDs drops dramatically for high luminance values. Degradation phenomena occur both under operating conditions and while the device is in storage, and result in a decrease in device luminance and an increase of the working voltage over time for a constant current density value. Three distinct degradation mechanisms have been identified in small-molecule-based OLEDs:⁴⁶ dark-spot degradation, catastrophic failure and intrinsic degradation. While the first two degradation modes can be reasonably solved by means of adequate control over the device fabrication conditions (clean room, glove-box, encapsulation), the intrinsic degradation mechanism is more challenging and still remains an issue for OLED technology and particularly for the blue colour. Significant activity is taking place in order to improve device lifetime by using new materials that are resistant to oxidation and by developing efficient encapsulation processes. High glass transition temperature (T_g) materials are desired in order to get stable devices under operation. Lifetimes now reported in the literature for the most advanced first generation RGB materials (fluorescent SM materials and polymers) are well over 20 000 h at room temperature and at least for luminance up to 100 cd m^{-2} . Nevertheless, the blue lifetime remains weaker (particularly for polymer materials) which could cause a red shift of the display due to differential ageing of RGB colours. Typical lifetime values are shown in Table 2 for the second generation of materials.⁴⁷ Efficient and stable blue phosphorescent materials are not yet available and remain a challenge for the chemist.

One has to keep in mind that the lifetime drops dramatically with increasing temperature, and most of the prototypes developed so far have a lifetime

Table 2. Current performance of new phosphorescent materials (data from Hack and Brown⁴⁷)

Colour	Current efficiency (cd A^{-1})	Lifetime (h)	CIE	
			x	y
Red	15 (at 500 cd m^{-2})	22 000 (at 500 cd m^{-2})	0.65	0.35
Green	29 (at 1000 cd m^{-2})	20 000 (at 1000 cd m^{-2})	0.31	0.64
Blue	19 (at 100 cd m^{-2})	<1 000 (at 200 cd m^{-2})	0.19	0.21

of 6000–8000 h at room temperature, which is not high enough for more demanding applications such as television or computer displays. In contrast to other display technologies, OLED displays can be fabricated on flexible substrates but so far such flexible devices have not reached the market owing mainly to their limited lifetime. Effective encapsulation (both on the bottom and top side of the device) of flexible OLED displays is still an industrial challenge. A review of thin-film permeation barrier technology for flexible OLEDs has been published recently.⁴⁸

DISPLAY TECHNOLOGY

Since the mid-1980s, these organics materials have been seen as a key component of a promising display technology likely to challenge liquid-crystal displays (LCDs). One of the characteristics of an LCD or an OLED display compared with a cathode-ray tube (CRT) is the layout of its active area consisting of pixels which form the images in an off or on state. The main feature of an OLED pixel is that it is an emissive device which can be switched off and be completely black, whereas a liquid crystal pixel is a transmissive device which does not allow complete occultation of backlight. Nevertheless, these two devices have a number of similarities that can pave the way toward OLED industrialization.

Passive-matrix displays

In the simplest case, a pixel is defined by the cross-over area of linear electrodes deposited on each side of the liquid crystal or of the emissive material in the case of an OLED. In such a configuration, the electrodes are oriented 90° from each other as shown in Fig. 4.

In the addressing method used for such matrix displays, each line is selected during a period of T/N , where T stands for the frame time and N for the number of lines of the display. During this period all the necessary pixels are activated according to the image content. Then, the next line is selected. In the case of a transducer without memory, it is necessary to refresh the image at a rate of at least 50 Hz in order to avoid any flickering effect. The frame time should then be less than 20 ms. The electrodes of a given pixel are shared with all the pixels of the same line and of the same column, and the voltage applied to it is controlled during the period in which the line is selected. For the rest of the frame time, the pixel may be subject to

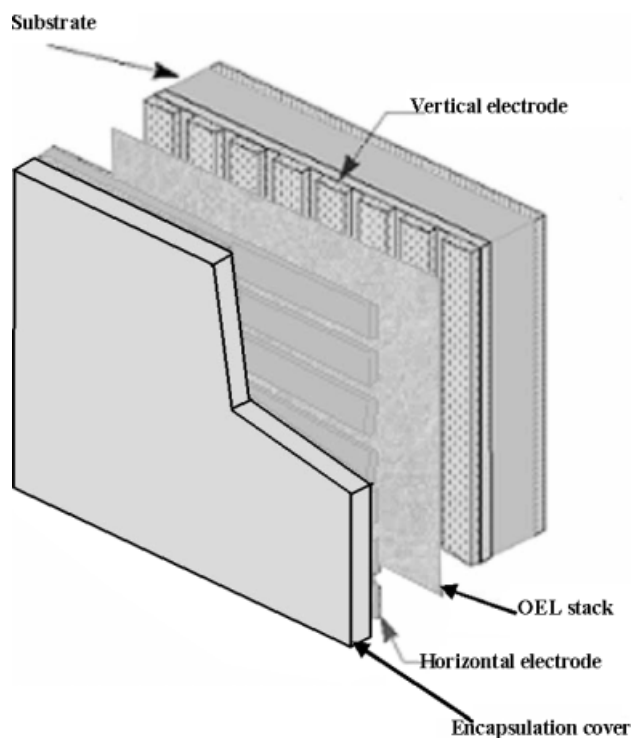

Figure 4. Principle of a passive-matrix display.

parasitic signals. Slow-response transducers (such as liquid crystals) are especially sensitive to such an effect, which alters the display contrast. One can demonstrate that for displays of more than 100 to 200 lines⁴⁹ the resulting contrast is not acceptable. In the case of fast-responding transducers (such as OLEDs), the issue lies in providing the pixels with the necessary current. In order to produce the desired luminous effect during a period of T/N and over a given column of pixels, it is necessary to increase the current level (and hence the voltage) proportionally to the number of lines (as an order of magnitude, for a display of 240 lines and an expected average luminance of 100 cd m^{-2} , the peak luminance required would be $24\,000 \text{ cd m}^{-2}$). This leads consequently to high power consumption (varying with the square of the voltage) and huge resistive losses in the columns on one hand, and stress and damage of the pixels (because of the high current) on the other hand.

Active-matrix displays

An alternative to the passive-matrix approach is active-matrix addressing, where each pixel is defined by its own electrode and driven by circuitry comprising a thin-film transistor (TFT) and capacitors, as depicted

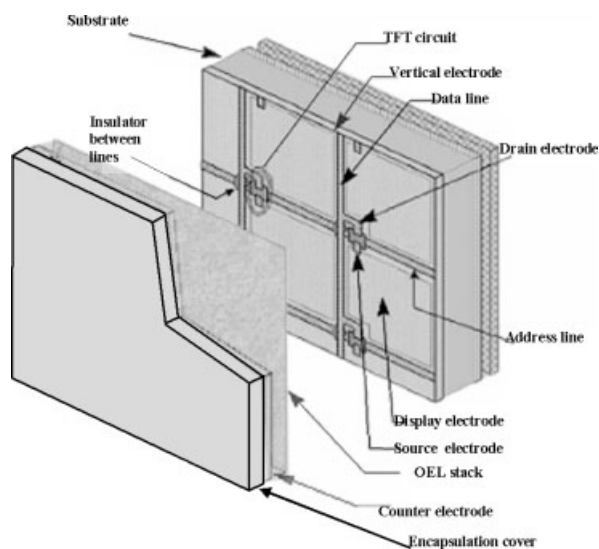

Figure 5. Principle of an active-matrix display.

in Fig. 5. The 'active' material (LCD or OLED) is then placed on top of this active-matrix circuitry and the counter electrode, which is not patterned, acts as a ground electrode. In such a device the capacitor is aimed at retaining the information during a frame period. In spite of the difficulties of fabrication of such matrixes, this technology is already widespread in flat-panel displays (FPDs) and is justified by the growing demand for large and high-resolution devices.

Addressing circuitry

The basic pixel circuit for an OLED active-matrix display consists of two TFTs and one capacitor (whereas for an LCD pixel only one TFT is required). As shown in Fig. 6, the switch TFT, T1 is used to select the line as the drive TFT, and T2 controls the value of the current to be delivered to the OLED. This latter TFT is kept in operation during the whole frame time by the voltage imposed by the capacitor. More precisely, when T1 is operational, the data signal V_{data} is imposed to the gate of T2 (V_{gs}). Assuming that T2 is operating in its saturation regime, the current I_{ds} is proportional to V_{gs} (and so is the luminance of the OLED, to a first approximation). Simultaneously, V_{data} is stored in the capacitor which will impose it to T2, thus keeping the current constant during the whole frame time. The main drawback of this simple circuit is its sensitivity to the non-uniformity of the TFT performance over the matrix; indeed, a variation in the characteristics of the TFT in two neighbouring pixels leads to different levels of luminance, which is not acceptable. However, numerous pixel circuits aimed at compensating these non-uniformities have been designed and successfully implemented.^{50–52} These circuits split into two main categories according to their mode of operation: the voltage-programmed addressing schemes and the current-programmed addressing one (NB: the terms 'voltage' and 'current' refer here to the operation mode of the circuit and not to the operation of the OLED itself).

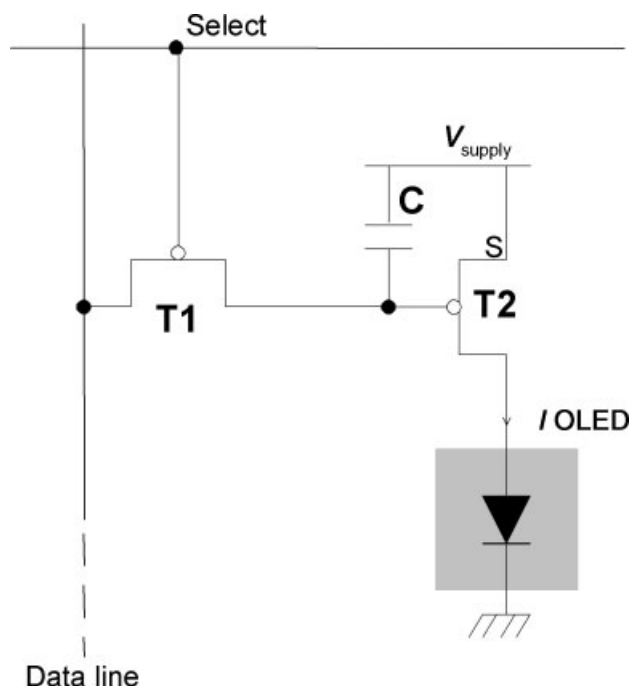

Figure 6. Basic pixel addressing circuit in an OLED active-matrix display. V_{supply} = voltage of the power supply.

Amorphous silicon TFT versus polysilicon TFT

Most of the active matrixes fabricated nowadays for active-matrix liquid-crystal displays (AMLCDs) are made of amorphous silicon (a-Si) deposited on a glass substrate by plasma-enhanced chemical vapour deposition (PECVD). Once deposited, the silicon layer (40–80 nm thick) is processed so that an array of TFTs and capacitors is obtained. This first step results in the deposition of an electrode which will be put in contact with the liquid crystal or the OLED. The field-effect mobility of such TFTs does not exceed $1 \text{ cm}^2 \text{ V}^{-1} \text{ s}^{-1}$. (n-type TFT) but is sufficient to drive an LCD pixel. These TFTs are known to be quite uniform over the display area owing to the uniformity of the a-Si itself.

However, owing to its higher electron and hole mobilities, polycrystalline silicon (p-Si) has been considered as a challenger to a-Si. The use of p-Si allows for smaller sized TFTs, making them suitable for high-definition display applications. Indeed, the field-effect mobility of such TFTs can currently reach $70\text{--}100 \text{ cm}^2 \text{ V}^{-1} \text{ s}^{-1}$. The pixel aperture ratio is larger than that of a-Si TFTs, leading to brighter displays with lower power consumption. Moreover, the pixel charging time decreases, facilitating a wider grey scale range and a higher video rate. In addition to these advantages of p-Si, the integration of driver circuitry is even more significant. The performance of p-Si TFTs allows simple circuits to be integrated at the outside edge of the display, reducing the number of interconnections and increasing the reliability. In 1999, Toshiba reduced the amount of internal connections on a 12.1 in XGA display by 95 % by integrating certain functionalities on the display. Overall, integration is seen as the

technological improvement that will allow substantial cuts in production costs. This capability is all the more valuable considering that the electronics cost represents a large percentage of the total cost in the case of small displays. Therefore, the trend in backplanes indicates that p-Si will be used in smaller displays and a-Si will be used in larger ones.

The characteristics of LCD and OLED displays differ from each other at that point. Indeed, an LCD is voltage-driven whereas an OLED display is current-driven. In other words, in an LCD display, a voltage is applied to the liquid crystal by a capacitor which is charged through a TFT. In an OLED display, as described above, the pixel is 'actuated' by the current flowing through the OLED stack and provided via a so-called drive TFT (see addressing circuit).

In LCDs, the TFT acts only during the time necessary to charge the capacitor; in the second case, the drive TFT is active during the whole frame time. For OLED displays, the voltage applied to the TFT, as well as its duty cycle, induce a degradation of the a-Si and consequently of the TFT. Therefore, p-Si is considered to be the more reliable material for use in active-matrix OLED displays. However, recent improvements in organic materials, which can be operated at low voltage, are resulting in renewed potential for the use of a-Si as a TFT core material.

High-temperature versus low-temperature p-Si

p-Si is usually obtained by annealing a-Si. Performed in a furnace, such a thermal process requires quartz substrates able to withstand high temperatures. Since the deposited silicon as well as the substrate are processed in a high-temperature environment, the resulting p-Si is called HTPS (high-temperature poly-silicon). However the cost of these quartz substrates limits their use to displays smaller than 6 in diagonal.

Excimer laser annealing (ELA), developed in the 1980s is now the most widespread way of annealing a thin silicon film. Indeed, the laser pulse energy and the incident energy density can easily be adjusted in order to control the melting of thin films, keeping the substrate at ambient temperature. Cheap glass can then be used as substrate material. This technique is known as the low-temperature poly-silicon process (LTPS). Such a treatment consists of irradiating the a-Si layer with an excimer laser (currently an XeCl laser emitting a radiation at 308 nm in pulses of 25–30 ns). The radiation is absorbed within 10 nm by the a-Si, leading to its fusion. Once the whole layer is melted, a solidification front is formed and progresses from the bottom of the layer up to the top, leaving a microcrystalline structure behind. Depending on the irradiation conditions (mainly the energy density), the size of the so-called Si grains currently range from a few tens of nm up to 1 μm .^{53–55} The performance of the TFT is directly related to this size. The main difficulty of this process is in keeping the laser parameters stable in order to obtain a uniform crystallization and, consequently,

a homogeneous TFT matrix. As explained below, this particular point has led to extensive research aimed at overcoming this non-uniformity issue by designing specific addressing circuits. In addition to this uniformity issue, this process is said to be 50 % more expensive than the a-Si one due to high capital expenditure and low yield.

OLED deposition

Depositing the organic materials onto the substrate to obtain red, green and blue pixels is a major challenge facing the industry. The requirements include, among others, accurate positioning and uniformity of the deposition. Small molecules are currently deposited by evaporation through a shadow mask, and polymers are mostly dispensed by inkjet printing.

Conventional photolithography cannot be used to pattern the pixels as the materials cannot withstand such a process and the layers are too thin.

Evaporation and shadow masking

This method consists of placing the small molecule materials in crucibles which are heated to 100–500 °C, under vacuum, thus inducing the evaporation of the organic powder. A thin (20–100 μm thick) shadow mask is placed above the crucible and the substrate is set on top of it (Fig. 7). The mask bears holes for one-third of the pixels. Once the stack of layers of one colour is deposited, it is shifted by one pixel to deposit the next set of pixels. In industrial equipment, each layer is deposited in a different chamber. The

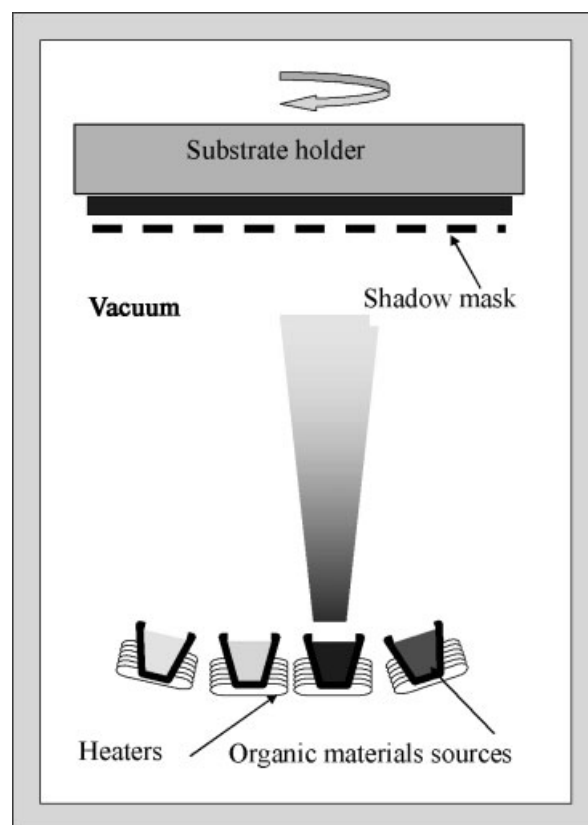

Figure 7. Principle of small molecule deposition by evaporation.

alignment of the substrate onto the mask should be done with a precision of $\pm 5 \mu\text{m}$. The accuracy and the handling of large shadow masks are among the main limitations of this technique. In all cases that use separate coloured emitters, a further problem is that each colour may have a different lifetime, as noted above. As one emitter ages faster than the others, the display colour will become unbalanced.

Cost-wise, the maintained vacuum in the chambers and the poor deposition efficiency of the point sources are the main drawbacks. However, this technique is now successfully employed in commercial applications. In a search to improve the deposition efficiency, systems have been designed in which the substrate moves perpendicularly and close to the linear evaporation sources. Such systems are not yet in use in industry.

Inkjet printing

This technique is used to dispense polymer materials which are soluble in a solvent. The solution is dispensed onto the substrate through inkjet nozzles (usually arranged by tens in a row). The droplets of a few picolitres are injected relatively accurately at the inkjet head. Although the positional accuracy of the inkjet tip is approximately $5\text{--}10 \mu\text{m}$, a slight shift in the angle is likely to occur leading to positional error which can be large compared with the pixel size. The problem is solved by patterning the substrate. Polyimide banks are built up around the pixel area, forming a well whose bottom is the pixel electrode. These banks are made water repellent and whereas the surface of the pixel is made hydrophilic to prevent the droplet from sticking on the banks and to ensure the pixel is filled properly (Fig. 8). Once deposited, the droplets are dried, the solvent is evaporated, and the film is formed. The pre-patterning of the substrates that is required as well as the difficulty in obtaining a uniform filling of the pixel after drying are currently limiting the interest in this technique, which is nevertheless considered to be the only solution for large area deposition. Seiko Epson and Cambridge Display Technology (CDT) have been developing inkjet printing techniques for OLEDs since 1996.

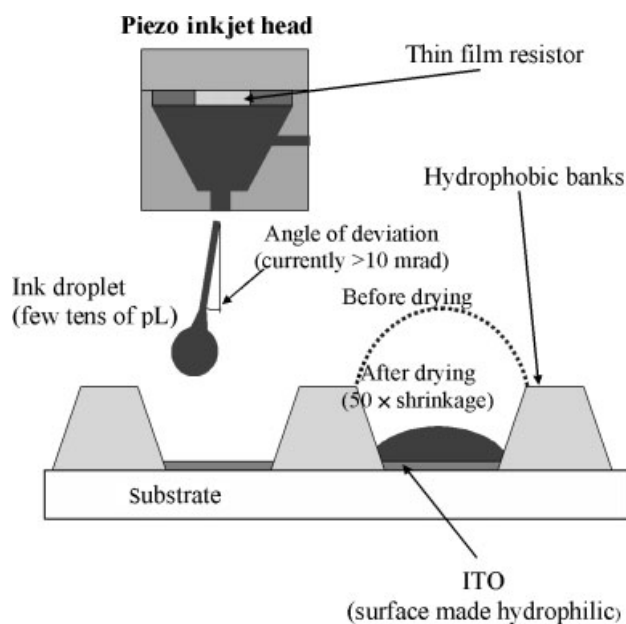

Figure 8. Principle of polymer deposition by inkjet printing.

Colour generation

A number of approaches have been tried for producing full-colour OLED displays, i.e. in fabricating red, green and blue pixels. The challenge is not only in patterning the pixels but also in having them constantly emitting light in a given ratio corresponding to a satisfactory white colour. This latter point relies mainly on the intrinsic performance of the materials themselves (typically their lifetime), but is the purpose of the particular approach described below.

Red, green and blue individual pixels

In addition to the difficulties of depositing individual pixels (see above), the shorter lifetime of the blue-emitting materials burdens this approach. However, the devices exhibit good optical performances since the light emitted is directly seen (Fig. 9(a)).

Blue emitter and colour converters

This approach is simpler, since only one colour of luminescent material is required.²³ The blue-emitting

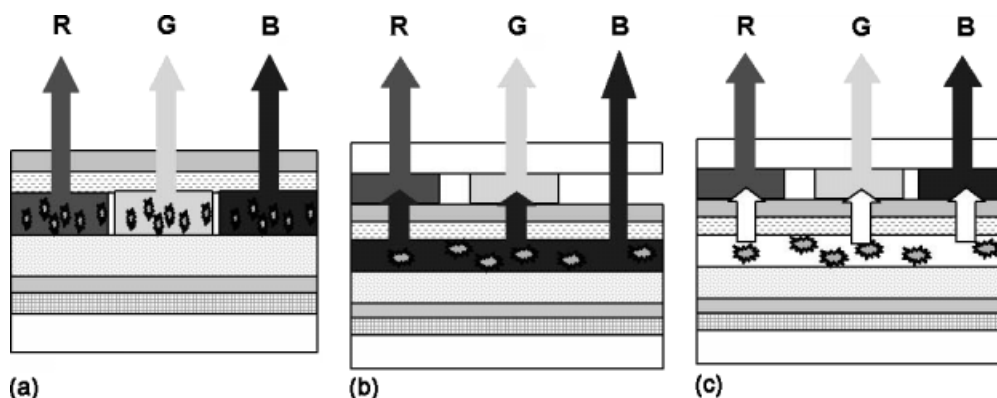

Figure 9. Principles of colour generation: (a) RGB individual pixels; (b) colour by blue emission and colour converters; (c) colour by white emission and colour filters.

structure is deposited first over the substrate and a red and green colour converter film is then positioned onto the display. No high-accuracy shadow mask is required. However, due to losses induced by conversion, the blue emitters must have high efficiency or be operated at a high current, which limit its lifetime (Fig. 9(b)).

White emitter and colour filters

This approach is similar to the previous one in so far as the emissive layers are deposited over the whole area of the display without any need to be patterned. Two or more luminescent materials are used to create white light, which is then turned into red, green and blue with the help of a colour filter film. Again this technique suffers from the loss through the filter (Fig. 9(c)).

Both the colour filters and the colour conversion films can be patterned using the same photolithography techniques developed for LCDs. The difficulties are associated with the efficiency of the colour conversion or the filtering. However, these two latter methods are considered to be a solution to the degradation in performance stemming from premature ageing of the blue emitters.

A fourth arrangement was invented at Princeton University and is being further developed by Universal Display Corp. This is the stacked OLED (or SOLED), in which each pixel contains red, green and blue emitters separated by transparent contacts. The potential advantage of the SOLED is a significant improvement in resolution, but it still suffers from brightness reduction.

Top and bottom emission

As the light is generated by the emissive layer in all directions, the OLED can be equally designed as bottom-emitting or top-emitting. In top-emitting devices, light flows through the cathode whose transparency limits the external luminance of the device. In bottom-emitting devices, light flows through the anode and, possibly, through the active backplane. In this case, the light is not only limited by the transparency of the anode but is also partially blocked by the circuitry which is all the more limiting the transmission as the addressing circuit bears more TFTs. The top-emitting configuration is thus highly preferable for a for-TFT pixel circuit, and bottom emission is considered acceptable with a basic two-TFT-based active matrix (Fig. 10).

CONCLUSIONS

At the end of the 1990s, OLEDs were seen as a disruptive technology for the display industry. Some of their advantages have now proven to be a breakthrough compared with LCDs. Its thickness, currently less than 2 mm (against 4–6 mm for LCDs), is one of them. This will decrease further as thin-film encapsulation will replace the glass or metallic lid currently used. The colour gamut now covers 80 % of NTSC and the

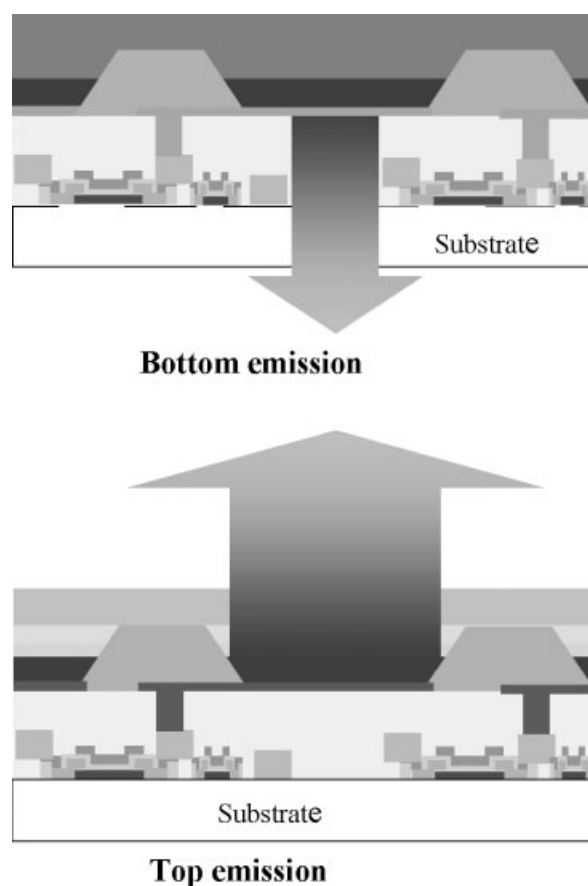

Figure 10. Top and bottom emission structures.

high contrast ratio is also a strong point of OLED technology. With regard to viewing angles, even though those of LCDs have increased significantly in recent years to reach 170° (but at a poor contrast ratio), this is still a major advantage of OLEDs. For high-speed video, OLED technology is also one step ahead thanks to its fast response time (a few tens of microseconds compared with milliseconds for LCDs). In terms of power consumption, which is crucial for mobile applications, transfective and reflective LCDs still perform well compared with the expected performances of OLEDs. One of the disadvantages of the organic materials is their individual lifetime: even though this has increased in recent years to reach about 10 000 h, it has to be improved further to prevent differential ageing of the colours and image sticking.

While 2005 and 2006 are expected to be breakthrough years for OLED technology in small- and medium-size displays, with revenue forecasts of \$832 million and \$1.2 billion, respectively (annual increases of 147 % and 47 %, respectively), its penetration will remain modest with about 5 % of the market in 2007.⁵⁶

REFERENCES

- 1 Helfrich W and Schneider WG, *Phys Rev Lett* **14**:229 (1965).
- 2 Tang CW and Van Slyke SA, *Appl Phys Lett* **51**:913 (1987).

- 3 Burroughes JH, Bradley DDC, Brown AR, Marks RN, Mackey K, Friend RH, Burns PL and Holmes AB, *Nature* **347**:539 (1990).
- 4 Burroows PE, Gu G, Bulovic V, Shen Z, Forrest SR and Thompson ME, *IEEE Transactions on Electron Devices* **44**:1188 (1997).
- 5 Wu CC, Wu CI, Sturm JC and Kahn A, *Appl Phys Lett* **70**:1348 (1997).
- 6 KIM JS, Cacialli F, Cola A, Gigli G and Cingolani R, *Appl Phys Lett* **75**:19 (1999).
- 7 Tang CW, Van Slyke SA and Chen CH, *J Appl Phys* **65**:3610 (1989).
- 8 Wakimoto T, Fukuda Y, Nagayama K, Yokoi A, Nakada H and Tsuchida M, *IEEE Transactions on Electron Devices* **44**:1245 (1997).
- 9 Hung LS, Tang CW and Mason MG, *Appl Phys Lett* **70**:152 (1997).
- 10 Heil H, Steiger J, Karg S, Gastel M, Ortner M, Von Seggern H and Stössel M, *J Appl Phys* **89**:420 (2001).
- 11 Jin YD, Ding XB, Reynaert J, Arkhipov VI, Borghs G, Heremans PL and Van der Auweraer M, *Org Electron* **5**:271 (2004).
- 12 Jabbour GE, Kippelen B, Armstrong NR and Peyghambarian N, *Appl Phys Lett* **73**:1185 (1998).
- 13 Li F, Tang H, Anderegg J and Shinar J, *Appl Phys Lett* **70**:1233 (1997).
- 14 Kang SJ, Park DS, Kim SY, Whang CN, Jeong K and Im S, *Appl Phys Lett* **81**:2581 (2002).
- 15 Zhou X, Pfeiffer M, Blochwitz J, Werner A, Nollau A, Fritz T and Leo K, *Appl Phys Lett* **78**:410 (2001).
- 16 Pfeiffer M, Leo K, Zhou X, Huang JS, Hofmann M, Werner A and Blochwitz-Ninotch J, *Org Electron* **4**:89 (2003).
- 17 Moliton A, *Molecular and Polymer Optoelectronics: from Concepts to Devices*. Springer Series in Optical Sciences. Springer, New York (2005).
- 18 Rotheberg LJ and Lovinger AJ, *J Mater Res* **11**:3174 (1996).
- 19 Köhler A and Wilson J, *Org Electron* **4**:179 (2003).
- 20 Greenham NC, Friend RH and Bradley DDC, *Adv Mater* **6**:491 (1994).
- 21 Hosokawa C, Higashi H, Nakamura H and Kusumoto T, *Appl Phys Lett* **67**:3853 (1995).
- 22 Wu YZ, Sun RG, Zheng XY, Zhu WQ, Jiang XY, Zhang ZL and Xu SH, *J SID* **12**:4:501 (2004).
- 23 Lemaitre N, Raimond P, Denis C, Maise P and Geffroy B, *Proceedings EL2004*, Toronto, Canada, September 20–23, p. 271 (2004).
- 24 Xie W, Hou J and Liu S, *Semicond Sci Technol* **18**:L42 (2003).
- 25 Ko YW, Chung CH, Lee JH, Kim YH, Sohn CY, Kim BC, Hwang CS, Song YH, Lim J, Ahn YJ, Kang GW, Lee N and Lee C, *Thin Solid Films* **426**:246 (2003).
- 26 Jabbour GE, Kawabe Y, Shaheen SE, Wang JF, Morrell MM, Kippelen B and Peyghambarian N, *Appl Phys Lett* **71**:1762 (1997).
- 27 Shi J and Tang CW, *Appl Phys Lett* **70**:1665 (1997).
- 28 Liu TH, Iou CY, Wen SW and Chen CH, *Thin Solid Films* **441**:223 (2003).
- 29 Ko CW and Tao YT, *Appl Phys Lett* **79**:4234 (2001).
- 30 Baldo MA, O'Brien DF, You Y, Shoustikov A, Sibley S, Thompson ME and Forrest SR, *Nature* **395**:151 (1998).
- 31 Adachi C, Baldo MA, Thompson ME and Forrest SR, *J Appl Phys* **90**:5048 (2001).
- 32 O'Brien DF, Baldo MA, Thompson ME and Forrest SR, *Appl Phys Lett* **74**:442 (1999).
- 33 Ikai M, Tokito S, Sukamoto Y, Suzuki T and Taga Y, *Appl Phys Lett* **79**:156 (2001).
- 34 Tokito S, Suzuki M and Sato F, *Information Display* **19**:22 (2003).
- 35 So FF and Forrest SR, *Phys Rev Lett* **66**:2646 (1991).
- 36 Ohmori Y, Fujii A, Uchida M, Morishima C and Yoshino K, *Appl Phys Lett* **63**:1871 (1993).
- 37 He G, Schneider O, Qin D, Zhou X, Pfeiffer M and Leo K, *J Appl Phys* **95**:5773 (2004).
- 38 Bulovic V, Tian P, Burrows PE, Gokhale MR, Forrest SR and Thompson ME, *Appl Phys Lett* **70**:2954 (1997).
- 39 Gu G, Parthasarathy G and Forrest SR, *Appl Phys Lett* **74**:305 (1999).
- 40 Dobbertin T, Kroeger M., Heithecker D, Schneider D, Metzendorf D, Neuner H, Becker E, Johannes HH and Kowalsky W, *Appl Phys Lett* **82**:284 (2003).
- 41 Pribat D and Plais F, *Thin Solid Films* **383**:25 (2001).
- 42 Qiu Y, Gao Y, Wang L, Wei P, Duan L and Zhang D, *Appl Phys Lett* **81**:3540 (2002).
- 43 Huang J, Yang K, Liu S and Jiang H, *Appl Phys Lett* **77**:1750 (2000).
- 44 Yang K, Huang J, Gao W and Liu S, *Thin Solid Films* **408**:206 (2002).
- 45 Liao LS, Klubek KP and Tang CW, *Appl Phys Lett* **84**:167 (2004).
- 46 Aziz H and Popovic ZD, *Chem Mater* **16**:4522 (2004).
- 47 Hack M and Brown JJ, *Information Display* **20**:12 (2004).
- 48 Lewis JS and Weaver MS, *IEEE J Selected Topics Quant Electron* **10**:45 (2004).
- 49 Budin JP, Stage de formation, Club Visu SID France (2001).
- 50 Kwon OK, *Asia Display/IMID2004 Workshop Proceeding*, p. 223 (2004).
- 51 Jung SH, Nam WJ and Han MK, *IEEE Electron Device Lett* **25**:690 (2004).
- 52 Sasaoka T, Sekiya M, Yumoto A, Yamada J, Hirano T, Iwase Y, Yamada T, Ishibashi T, Mori T, Asano M, Tamura S and Urabe T, *SID01 Digest*, p. 384 (2001).
- 53 Pribat D, Legagneux P, Plais F, Petinot F, Huet O and Reita C, *Annales de Physique Coll C1* **22**:(1997).
- 54 Thompson CV and Smith HI, *Appl Phys Lett* **44**:603 (1984).
- 55 Watanabe H, Miki H, Sugai S, Kawasaki K and Kioka T, *Jpn J Appl Phys* **33**:4491 (1994).
- 56 Young B, *Information Display* **21**:22 (2005).